

# C Axis – Height Offset

**When to use:** Setting the Height Offset to the correct height is critical to successfully using C Axis aggregates. Listed below are Height Offset positions for 4 major types of aggregates.

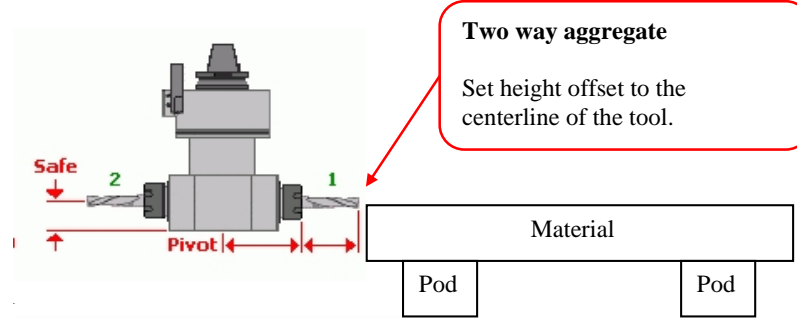

## Two way aggregate

Set height offset to the centerline of the tool.

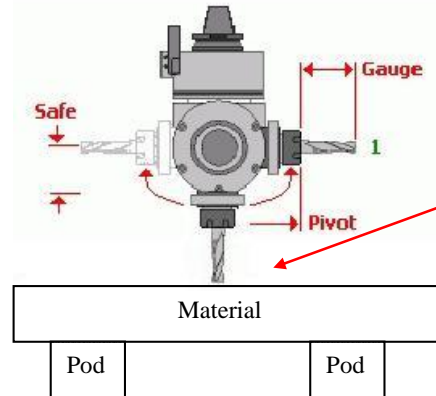

## Adjustable aggregate

Set height offset on adjustable aggregate with aggregate straight down at zero degrees.

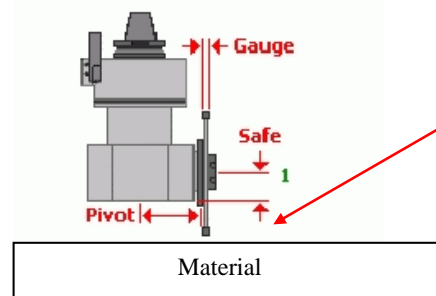

## Saw aggregate

Set height offset to outside edge of saw.

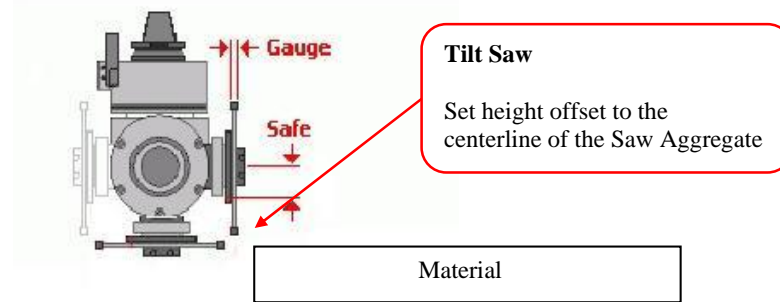

## Tilt Saw

Set height offset to the centerline of the Saw Aggregate

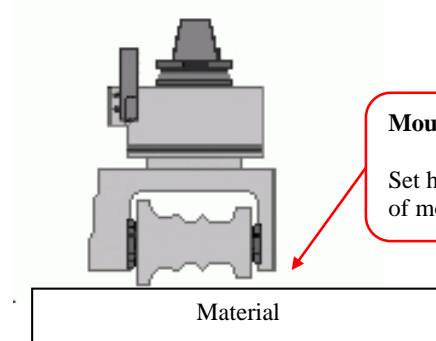

## Moulder Head

Set height offset to the bottom of moulder tool.

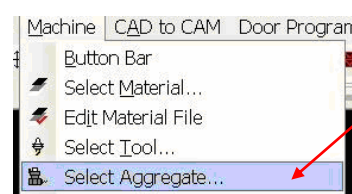

## To Activate Aggregate Macro Menu.

**Note :** If Menu is not active make sure **Productivity Pack** is loaded and go to *Utils – Add Ins* and make sure *Select Aggregate* is checked.

Sets starting rotation position of the aggregate

Click on Get aggregate

Click on Get tool from tool library

